

GMP80P Portable Carbon Dioxide Probe with Pump Sampling



Features

- Measurement range 0–20 %CO₂
- Operating temperature range +15 ... +40 °C (+59 ... +104 °F)
- Easy CO₂ sampling through standard incubator sampling ports
- Stainless steel pipe and plastic tube options for sampling
- Compatible with Vaisala Indigo80 Handheld Indicator and Insight PC software
- Excellent long-term stability
- Reliable and accurate
- Calibration certificate included

Vaisala CARBOCAP® Portable Carbon Dioxide Probe with Pump Sampling GMP80P combines intelligent CO₂ measurement with pump-aspirated sampling functionality. This robust and portable measurement device is designed for use in demanding applications, such as life science incubators, where stable, reliable, and accurate performance is required.

GMP80P is ideal for:

- CO₂ sampling from incubators
- Spot-checking fixed CO₂ transmitters
- Sampling from areas otherwise difficult to access

Ease of use with Indigo80

CO₂ measurement data can be monitored with the compact Vaisala Indigo80 Handheld Indicator connected to GMP80P. Indigo80 can be used for short-time logging of measurement data, as well as for calibrating and adjusting GMP80P.

Indigo80 has two cable ports for connecting Vaisala probes or transmitters to the indicator for measuring a wide range of parameters. GMP80P is powered by Indigo80, which can supply power for up to two GMP80P probes.

For more information on Indigo80, see vaisala.com/indigo80.

Flexible connectivity

For easy access to field calibration, device analytics, configuration functionality, and powering, GMP80P can also be connected to a PC running Vaisala Insight PC software for Windows®. For more information on Insight, see vaisala.com/insight.

Applications

GMP80P is ideal for life science incubators and for all demanding applications where stable and accurate percentage-level measurements are needed.



Technical data

Measurement performance

Measurement range	0–20 %CO ₂
Accuracy ^{1) 2)}	
At 5 %CO ₂	±0.1 %CO ₂
At 0–8 %CO ₂	±0.2 %CO ₂
At 8–20 %CO ₂	±0.4 %CO ₂
Calibration uncertainty	
At 5 %CO ₂	±0.07 %CO ₂
At 20 %CO ₂	±0.27 %CO ₂
Long-term stability	
At 0–8 %CO ₂	±0.3 %CO ₂ /year
At 8–12 %CO ₂	±0.5 %CO ₂ /year
At 12–20 %CO ₂	±1.0 %CO ₂ /year
Start-up, warm-up, and response time	
Start-up time at +25 °C (+77 °F)	< 10 s
Warm-up time to full specification	< 4 min
Response time (T90)	< 1 min
Other	
Sampling frequency	1 s

1) At 25 °C (77 °F) and 1013 hPa (incl. repeatability and non-linearity).

2) As the gas sample dries during the sampling process, the CO₂ concentration of the dry sample will be higher than in the wet sample taken in the measurement environment. This is due to water condensing off the warm gas sample as it cools down. To determine the most accurate measurement values in your sampling environment, see GMP251 and GMP80P User Guide (M211799EN) at docs.vaisala.com for a table listing the dilution coefficients for gas samples taken at different temperatures.

Operating environment

Operating environment	Indoor use
Operating temperature	+15 ... +40 °C (+59 ... +104 °F)
Storage temperature	-20 ... +60 °C (-4 ... +140 °F)
Operating humidity	0–95 %RH
Storage humidity	20–85 %RH
IP rating	IP4X
Flow rate of sampled/aspirated gas	0.3 l/min

Powering

Operating voltage	12–30 V DC
Power consumption	Typical: 0.7 W Maximum: 0.9 W
Current consumption	60 mA typical at minimum voltage

Digital communication

Digital output	RS-485
----------------	--------

Compliance

EU directives and regulations	EMC Directive (2014/30/EU) RoHS Directive (2011/65/EU) as amended by 2015/863 REACH Regulation (EC 1907/2006)
Electromagnetic compatibility (EMC)	EN 61326-1, basic electromagnetic environment FCC part 15 B, Class B ICES-3 / NMB-3 (Class B)
Compliance marks	CE

Mechanical specifications

Cable connector type	M12 5-pin A-coded male
Barbed fitting for gas outlet (optional)	For tube with ID 4 mm (approx. 5/32 in)
Dimensions (H × W × D)	
Probe body (incl. cable connectors), without sampling pipe:	114 × 102 × 40 mm (4.49 × 4.02 × 1.57 in)
Depth with sampling pipe:	145 mm (5.71 in)
Weight	410 g (14.46 oz)
Materials	
GMP80P (excluding GMP251 probe):	
Housing	Aluminum and polyamide
Sampling pipe	Stainless steel
Barbed fitting for gas outlet	Nickel-plated brass
Connectors (on the bottom)	Nickel-plated brass
GMP251 probe:	
Housing	PBT polymer
Filter	PTFE membrane, PBT polymer grid
Connector	Nickel-plated brass

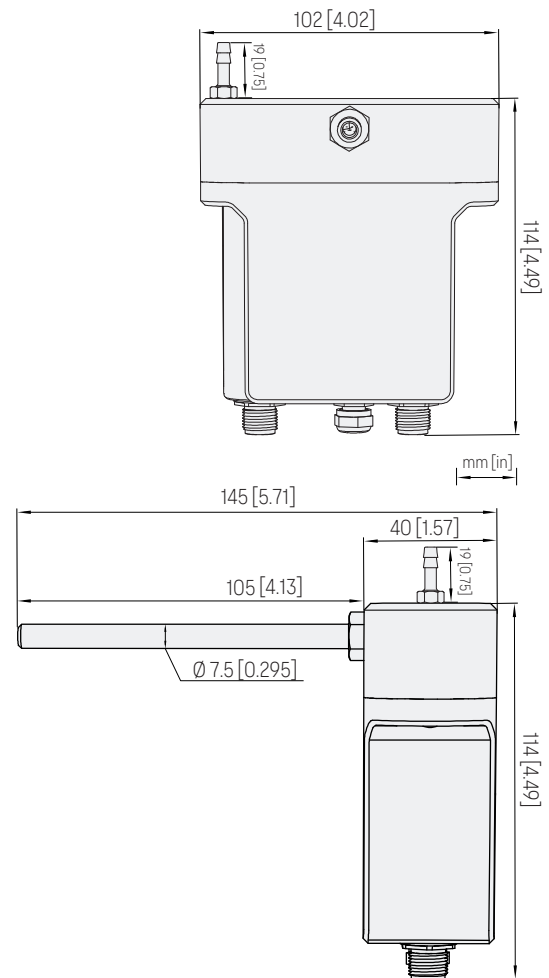

GMP80P dimensions, front and side

Spare parts and accessories

GMP251 CO ₂ probe	Configuration code A1COC0N1 ¹⁾
Cable for probes (M12-M12), 1.5 m (4 ft 11 in)	272075SP
Sampling pipe (stainless steel), 100 mm (3.94 in)	DRW259158SP
Sampling tube (Nafion™ membrane and PUR), 2.1 m (6 ft 11 in) ²⁾	GMTUBESP
Sampling tube (Nafion™ membrane), 0.6 m (1 ft 12 in)	212807SP
Sampling tube (PUR), 1.5 m (4 ft 11 in)	279471SP
Adapter for sampling tube	279473SP
Barbed fitting for gas outlet	279524SP
Magnetic hanger	ASM214318SP
Indigo USB adapter	USB2

1) See the GMP251 Order Form at docs.vaisala.com for more information.

2) Consists of a 0.6-m (1 ft 12 in) Nafion™ tube and a 1.5-m (4 ft 11 in) polyurethane tube.